

R146CX004

R146CX005
R146C

Description

The **R146C** adjustable magnetic dirt separator separates and removes debris inside hydraulic circuits of modern heating and cooling systems. Impurities are separated by the combined action of water centrifugal force, a magnet and a metal filter. They can be then discarded by the drain cock. The special adjustable fitting enables to install the R146C dirt separator under-boiler, on horizontal, vertical, angled and also 90°-angled pipes.

Versions and product codes

Product code	Connection
R146CX004	3/4" M (ISO 228)
R146CX005	1" M (ISO 228)

Components included with the R146C dirt separator

- Cap for inlet/outlet fitting (3/4" F or 1" F depending on the codes)
- 1/2" M x 3/4" F adjustable drain cock
- Magnet with brass housing

Optional accessories for R146CX004

- R254PY034: shut-off ball valve, 3/4" F flat seat nut (ISO 228) x 3/4" M (ISO 228)
- R176PY008: tail piece, 3/4" F flat seat nut (ISO 228) x 3/4" F (ISO 228)

Optional accessories for R146CX005

- P15FY005: pair of two tail pieces, 1" F flat seat nut (ISO 228) x 1" F (Rp - EN10226)

Technical data

- Fluid: water, glycol-based solutions (max. 50 % of glycol)
- Temperature range: 5÷90 °C
- Max. inlet pressure: 10 bar
- Filter: 300 µm









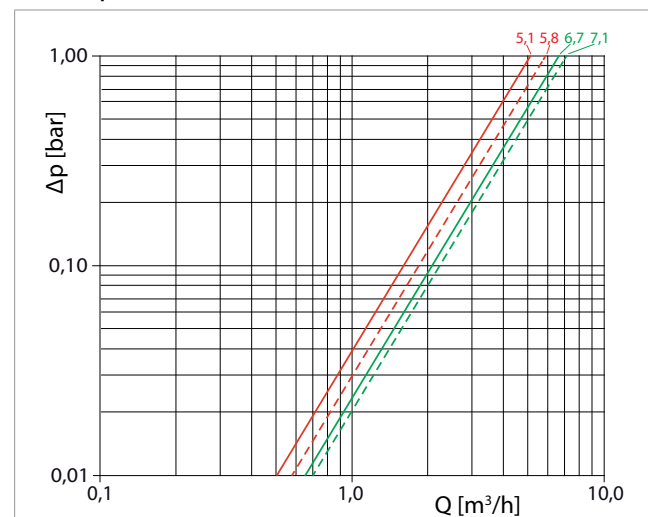

Note.
For use with higher temperatures and/or pressures, replace the drain cock with a brass plug (code R92X003).

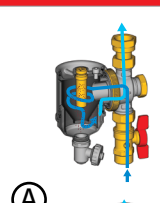
Materials

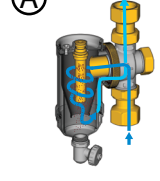
- Body and inlet/outlet fitting: brass CW617N - UNI EN 12165 nickel plated
- Cyclonic chamber: nylon 66 glass-filled 30 % (PA66GF30)
- Filter: AISI 304 stainless steel
- Gaskets: EPDM
- Magnet: neodymium (N35H)

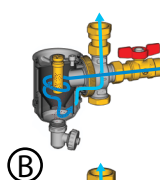
Losses of pressure

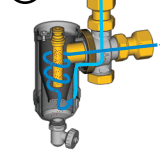

Configurazione	Curva sul grafico	Kv
	 R146CX004 (3/4")	5,1
	 R146CX005 (1")	6,7
	 R146CX004 (3/4")	5,8
	 R146CX005 (1")	7,1

Components

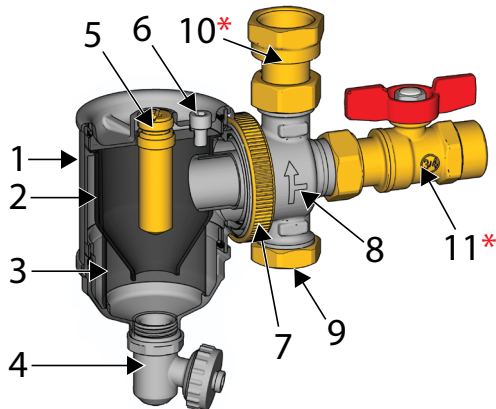

Legend

1	Dirt separator body
2	Cyclonic chamber
3	Filter
4	Adjustable drain cock
5	Magnet housing and magnet
6	Air vent screw
7	Fitting lock nut
8	Adjustable inlet/outlet fitting
9	Cap (3/4"F or 1"F depending on the codes)
10	3/4"F x 3/4"F flat seat tail piece *(Optional)
11	3/4"M x 3/4"F interception ball valve *(Optional)

Operation



The water flows into the dirt separator and is then channeled into the cyclonic chamber where a vortical motion enhances particle separation; this area also features a magnet that retains metal impurities.

A metal filter below the cyclonic chamber holds the impurities decanting from the chamber itself on the bottom of the separator.

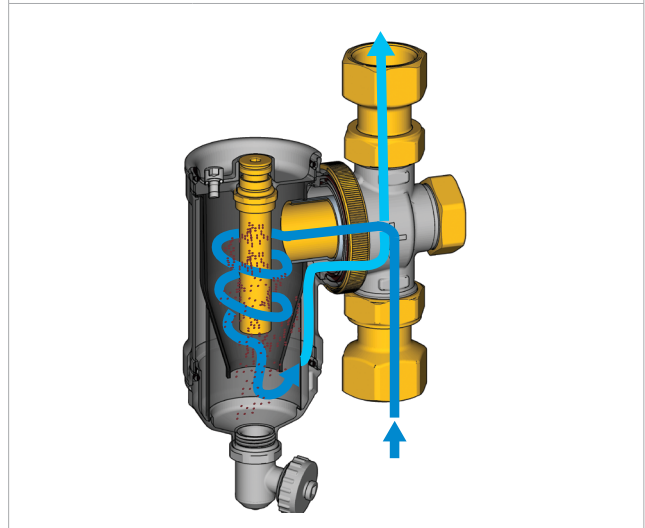
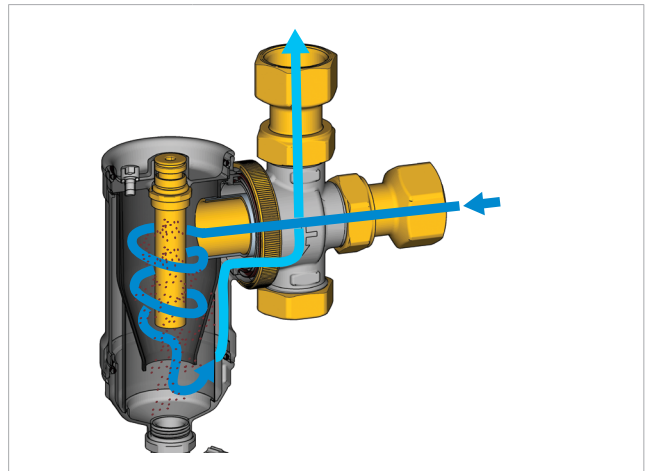
The dirt separator features a screw on top which releases air upon initial operation (see "Installation" paragraph).



Legend

	Impure water flowing into the dirt separator
	Impurity-free water flowing out from the dirt separator

The separator can be cleaned without being disassembled and/or switching off the system by opening the drain cock on the bottom of the separator - after pulling out the magnet from its housing from the top (see "Maintenance" paragraph).

Installation

In order to protect the boiler from the impurities in the pipes, the R146C dirt separator must be installed on the heating return circuit.

Its compact size enables to install it right under a wall-mount boiler.

Leave a free space on the upper side of the separator, at least 50 mm, to easily remove the magnet.



Note.
To facilitate maintenance operations, it is recommended to install a shut-off valve upstream and downstream of the R146C dirt separator.

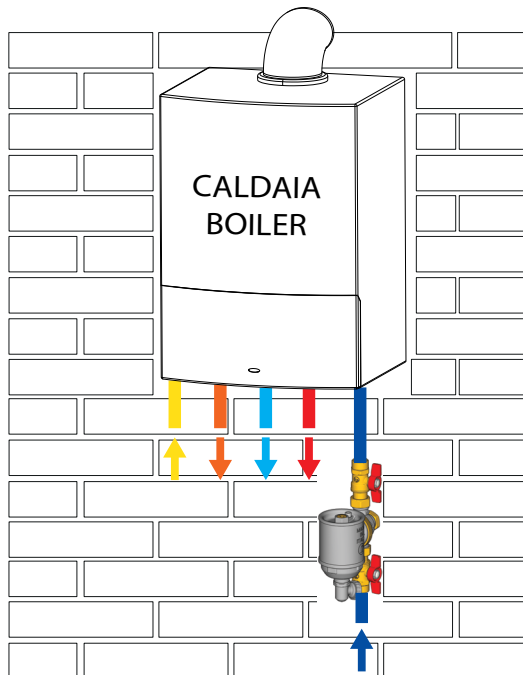
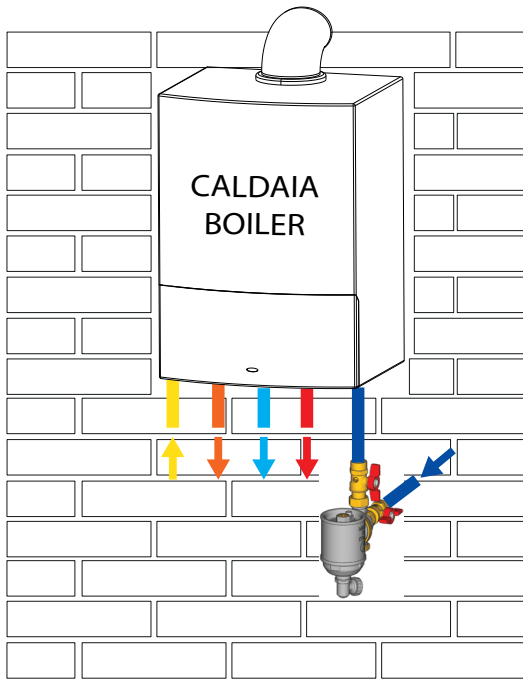

Legend

	Heating system return
	Heating system delivery
	Sanitary cold water
	Sanitary hot water
	Gas supply

Loosen the ring nut (ref. 7 - Components) to adjust the orientation of the water outlet/inlet fitting (ref. 8 - Components), place the fitting in the desired position and tight the ring nut.

Screw the cap included with the dirt separator, on the unused inlet.

The main body should always be in vertical position with the drain facing down.

To drain the impurities decanted on the bottom of the separator is possible to open the adjustable drain cock (ref. 4 - Components).

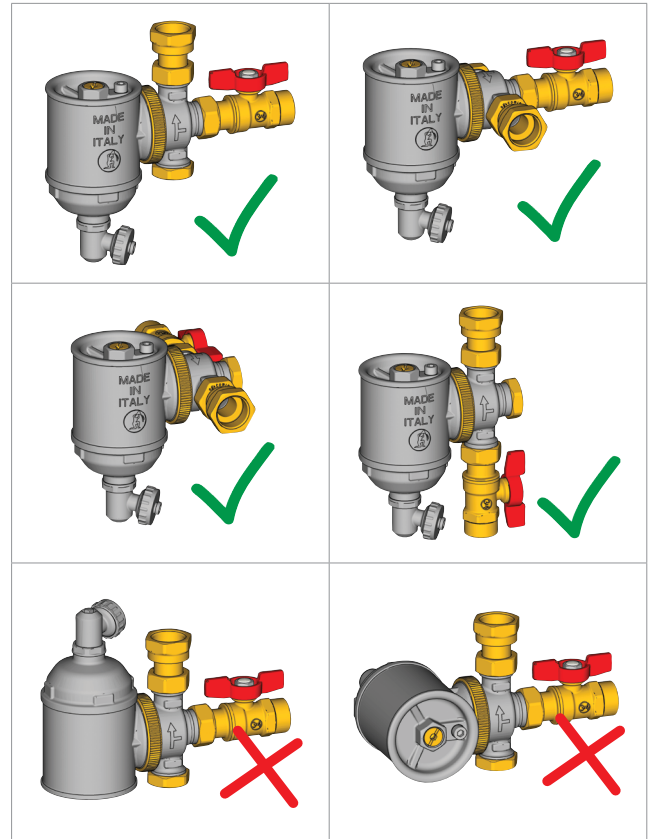

Warning.

The dirt separator is equipped with a magnet that causes magnetic fields, which may damage electronic devices (pacemakers included) near the circuit.



Air vent screw

On top of the dirt separator is a screw to vent air from the system during first operation (ref. 6 - Components).

Release the air by turning the screw in anticlockwise direction with a 5 mm Allen spanner.

Tighten the screw clockwise once the air has been removed.

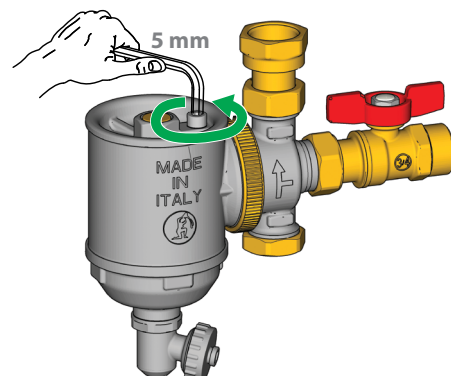

Maintenance

How to clean the dirt separator

During system operation, impurities collect on the surface of the magnet housing and on the bottom of the dirt separator. The dirt separator requires no disassembling and shutting off to be cleaned; however we recommend carrying out these operations with no flow inside the dirt separator.

To clean the separator and remove impurities, follow the steps below:

- 1) Shut off the interception ball valve.

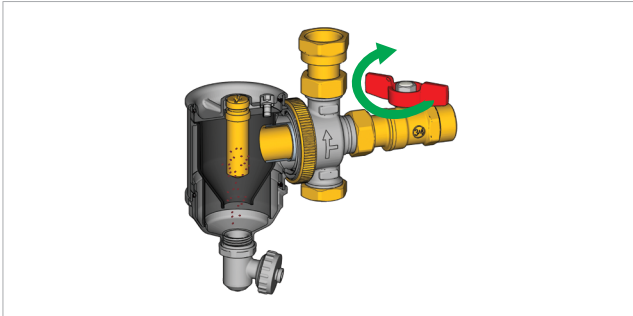

- 2) Pull out the magnet from its housing by unscrewing it in counter-clockwise direction with a 5 mm Allen spanner. The impurities collected on the housing surface will deposit on the bottom of the separator.

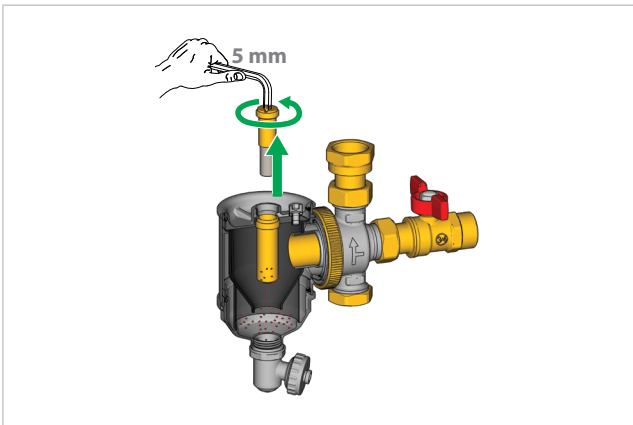

- 3) After a few minutes, take the cap from the drain cock, and place it on the bottom of the cock, then rotate counter-clockwise to open the drain cock and discharge the impurities in the dirt separator.

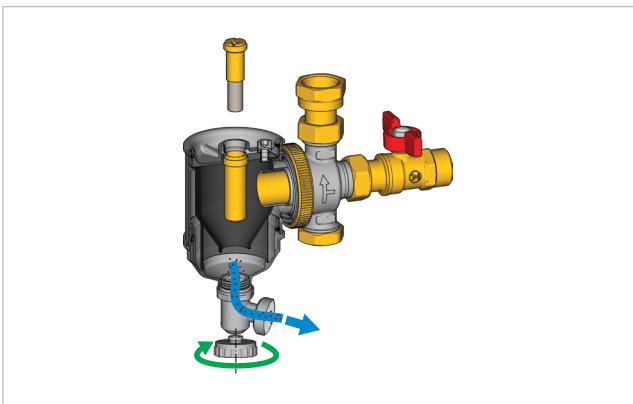

- 4) Once the impurities have been removed, close the drain cock and reinsert the magnet in its housing, screwing it in counter-clockwise direction. The separator will start working normally.

Removing the filter

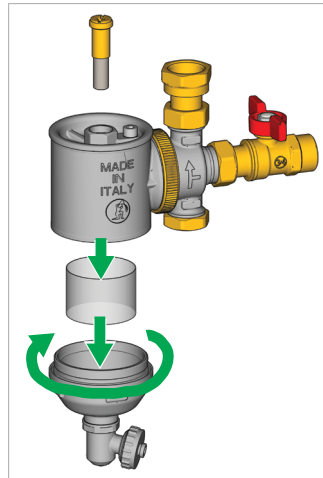

For a more thorough cleansing, proceed as follows:

- 1) Turn off the system and intercept the fluid with ball valves, upstream and downstream of the separator to prevent water from flowing inside the dirt separator.
- 2) Unscrew the dirt separator base in counter-clockwise direction.
- 3) Remove the filter from the dirt separator to clean it.
- 4) Fit the filter back in and screw the separator back on its base.

Dimensions

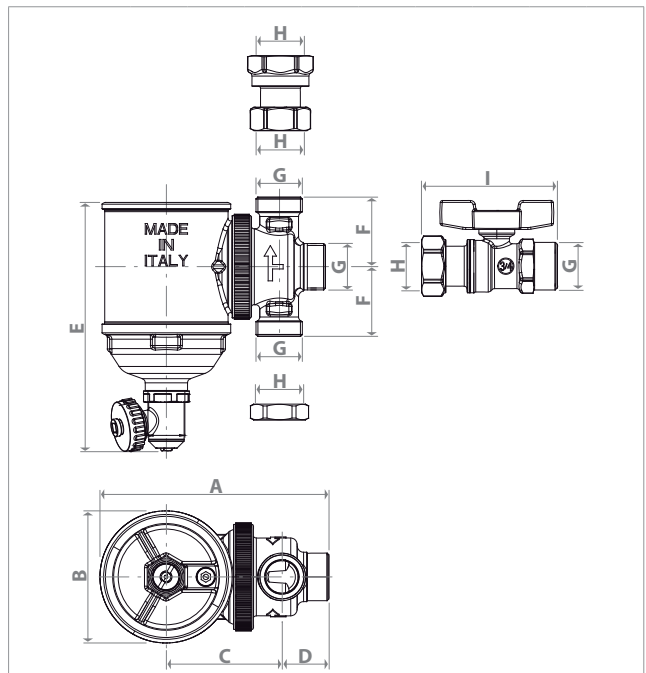

Product code	A [mm]	B [mm]	C [mm]	D [mm]	E [mm]	F [mm]	G [mm]	H [mm]	I [mm]
R146CX004	126,5	73	64	26	141	39,5	3/4" M	3/4" F	75
R146CX005	139	73	70	33	186	43	1" M	1" F	-

Product specifications

R146C

Adjustable magnetic dirt-separator, equipped with inlet/outlet fitting with 3/4" M ISO 228 or 1" M ISO 228 connections, 3/4" F or 1" F cap, adjustable drain cock, magnet and brass magnet housing. Brass body CW617N - UNI EN 12165. Cyclonic chamber made of synthetic material. Filter 300 µm. EPDM gaskets. Neodymium magnet. Temperature range 5÷90 °C. Max. working pressure 10 bar. Fluid: water, glycol-based solutions (max. 50 % of glycol).

Additional information

For more information, go to www.giacomini.com or contact our technical assistance service: ☎ +39 0322 923372 📞 +39 0322 923255 ✉ consulenza.prodotti@giacomini.com
 This document provides only general indications. Giacomini S.p.A. may change at any time, without notice and for technical or commercial reasons, the items included herewith.
 The information included in this technical sheet do not exempt the user from strictly complying with the rules and good practice standards in force.
 Giacomini S.p.A. Via per Alzo, 39 - 28017 San Maurizio d'Opaglio (NO) Italy